

# Generalized Faulty Block Model for Automatic Test Pattern Generation

F. Podyablonsky, N. Kascheev



# Outline

- Continuous model of digital circuit
- ATPG technique
- Faults modeling method
- Experimental results

# Continuous approach

Continuous analogues for logic functions

$$Q(X), X = (x_1, \dots, x_n), x_i \in \{0, 1\}, i = \overline{1, n}$$

$$\tilde{q}(\tilde{X}), \tilde{X} = (\tilde{x}_1, \dots, \tilde{x}_n), 0 \leq \tilde{x}_i \leq 1, i = \overline{1, n}$$

$$Q(X) = \tilde{q}(X), \forall X \mid x_i \in \{0, 1\}, i = \overline{1, n}$$

Logic function	Continuous analogue
$Y = \overline{X}$	$\tilde{y} = 1 - x$
$Y = X_1 \wedge X_2$	$\tilde{y} = x_1 x_2$
$Y = X_1 \vee X_2$	$\tilde{y} = x_1 + x_2 - x_1 x_2$
$Y = X_1 \oplus X_2$	$\tilde{y} = x_1 + x_2 - 2x_1 x_2$

# ATPG technique

Constructing objective function

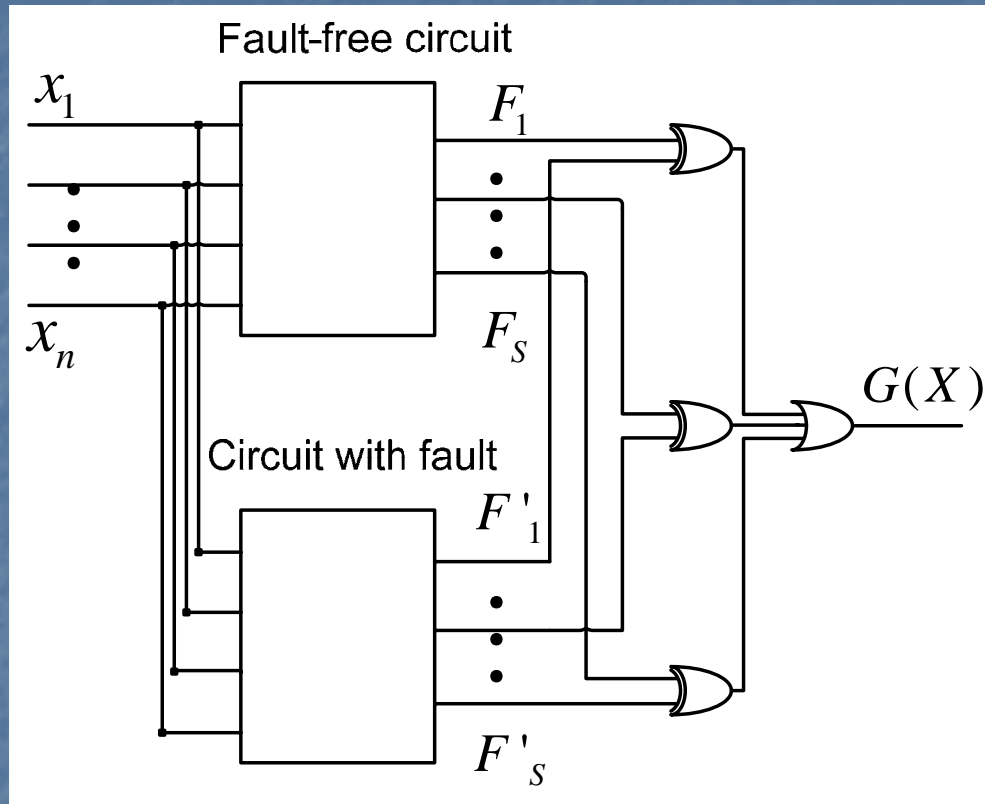

$$G(X) = \bigcup_{k=1}^s (F_k(X) \oplus F'_k(X)) = 1 \Leftrightarrow$$

$\Leftrightarrow X = (x_1, \dots, x_n), \quad x_i \in \{0, 1\}, i = \overline{1, n}$  – test pattern for the fault considered

$$\tilde{G}(\tilde{X}) = 1, \quad \tilde{X} = (\tilde{x}_1, \dots, \tilde{x}_n), \tilde{x}_i \in [0, 1], i = \overline{1, n}$$

# Faults modeling

Introducing a faulty block

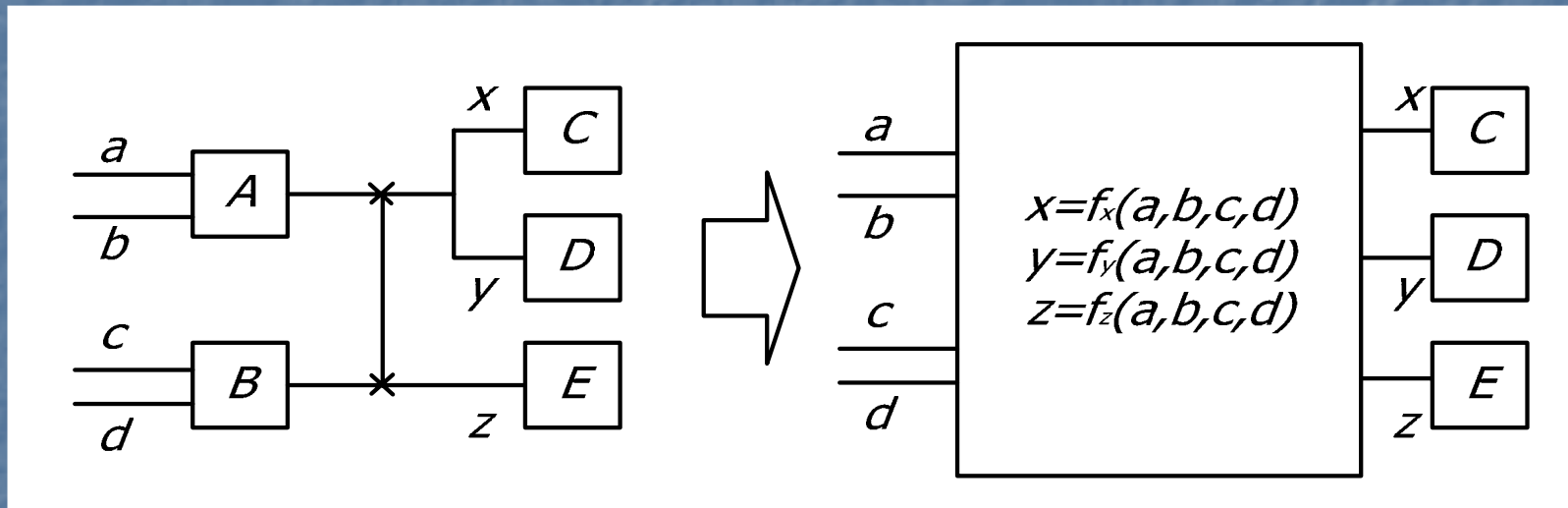

Common approach to different fault types modeling at the test pattern generation phase:

- stuck-at
- bridges (wired logic model, voting model, resistive model, ...)
- opens

# Experimental results

ATPG results for stuck-at faults in combinational circuits

Circuit	Faults			Coverage, %	Time, s
	Total	Detectable	Covered		
c432	524	520	520	100	0.86
c499	758	750	750	100	1.72
c880	942	942	942	100	1.25
c1355	1574	1566	1566	100	4.47
c1908	1879	1872	1861	99.41	4.53
c3540	3428	3297	3276	99.36	26.32
c5315	5350	5291	5267	99.55	19.56
C6288	7744	7710	7710	100	24.93

# Experimental results

ATPG results for resistive bridges in sequential circuits

Circuit	Faults considered	Faults covered	Time, s
s27	29	29	1.52
s208	5334	5112	310.42
s298	7973	7689	237.55
s386	10000	9357	286.24
s641	10000	9870	315.23
s953	10000	9763	925.15

**Thank you for attention**

EWDTs 2009, Moscow, Russia, September 18 -21